

Installation Instructions

The AGDS-MC v2 is a multi channel gas detection system designed for use in boiler houses. Six low voltage detectors can be connected (16 with a power pack) for the detection of natural gas, LPG, or carbon monoxide, carbon dioxide and oxygen depletion.

In the event of a high alarm from one of the detectors, the system will isolate a connected control valve. Low alarm indication is also given.

Even with the system switched off it can still be used to monitor for carbon monoxide and dioxide via its 0-10v output and BMS relays. Should there be an issue from a solid fuel appliance it can raise an alarm or switch ventilation on via a relay.

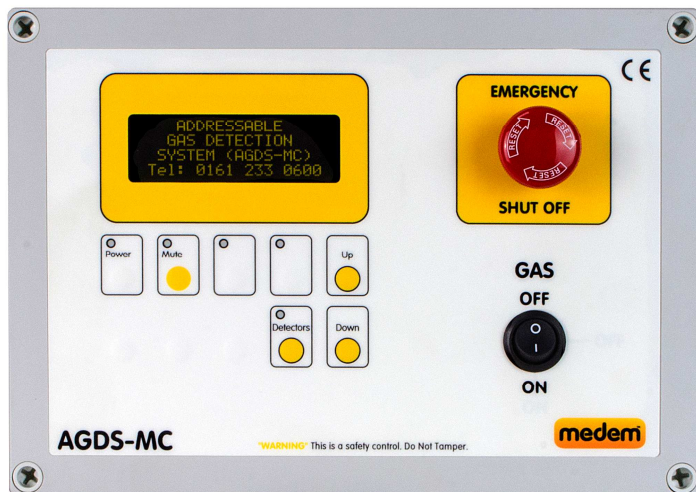

- Gas Detection . (Up to 16 detectors, with power pack)
- Natural gas, LPG, carbon monoxide & carbon dioxide
- Remote emergency stops
- Fire Alarm input monitoring
- BMS relay (Settable)
- 5 year warranty - 10 years when commissioned

AGDS-MC features

Before commencing installation please familiarise yourself to the equipment by reading the comprehensive installation instructions. If in doubt then please call 0161 233 0600. Out of hours please call 07894 684080 or 07843 355163.

It is a statutory requirement that this safety system is installed and commissioned to the satisfaction of the manufacturer.

A commissioning certificate must be issued to the end user along with instructions for the operation of the equipment.

As the Manufacturer, Medem UK should commission this safety system whereupon a commissioning report will be forwarded to the installing agent who should provide a copy to the end user.

At the point of our commissioning an individual serial number will be attached to the system along with a 24 help line number. Photos and all relevant information for the installation will then be stored on the Medem site database to be accessed in the event of a call on the 24 hour help line. The warranty period for the panel and sender unit will then be extended to Ten years.

The AGDS-MC is a gas detection system designed to monitor the atmosphere for target gases.

The system comprises of a mains powered panel capable of operating up to six combustible and two carbon monoxide detectors (or 16 total in conjunction with the AD-PP transformer pack). Combustible, Carbon Monoxide, Carbon Dioxide & Oxygen are available.

The detectors are pre-calibrated by Medem (UK) Ltd such that they only require to be connected to the panel and functionally tested.

In the event of a high alarm from one of the detectors the system will isolate the gas supply by closing a connected electric control valve. Emergency stop buttons and Thermal Links can be fitted and a fire alarm can close the gas valve when connected to the panel.

Control Panel

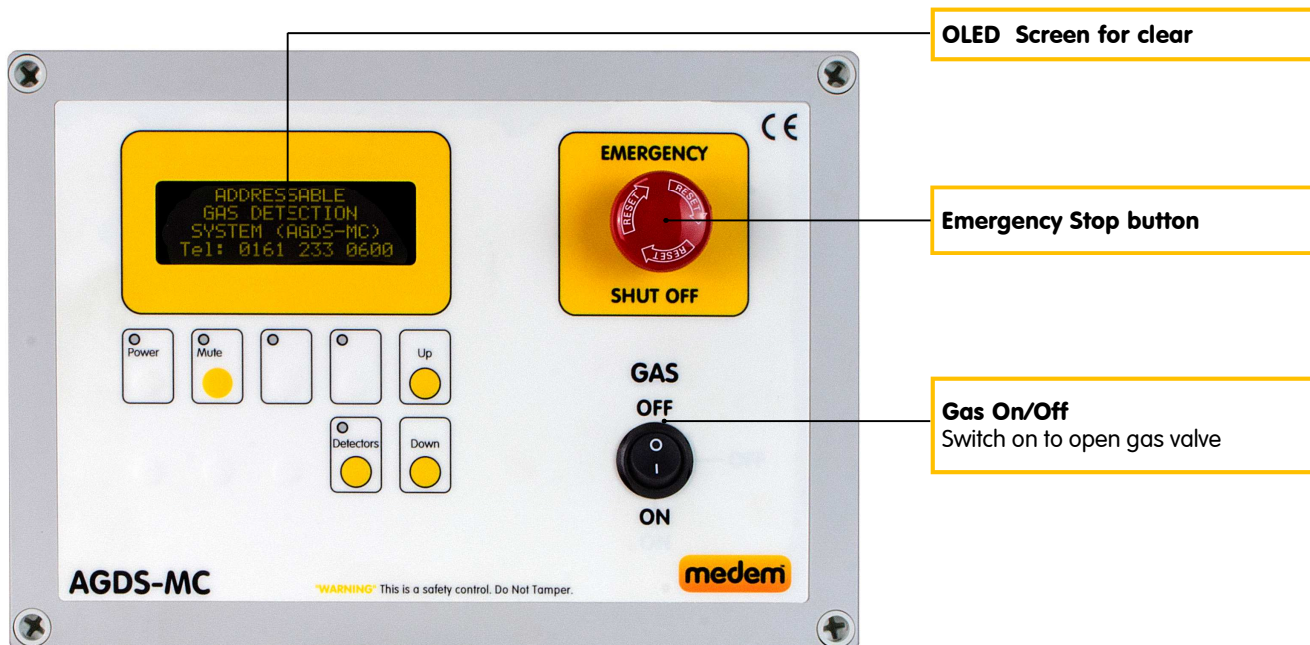

Low Voltage Gas Detectors

Combustible detectors are set to alarm at 5% LEL (pre alarm) and 10% LEL for the high alarm.
 Carbon Monoxide detectors are set to alarm at 20ppm (pre alarm) and 30ppm for high alarm.
 Carbon Dioxide detectors have settable high alarms of 1500, 2200, 4000, & 5000 PPM's
 Oxygen depletion detectors are set to alarm at 19.5% (pre alarm) and 18% (high alarm)

Connect a detector to the "detectors terminals" (11&12), each detector has a rotary address selector switch (0-F) set to a unique address. Once connected and addressed you are required to press the "learn Field Devices" button (21).

Each gas sensor unit has an LED which shows green when power is applied.

Note: There is a warm up period after initial power up of approximately 90 seconds. During this time the green LED will flash once per second and the output signal will be inhibited. This is to prevent spurious alarms. After the warm up period and on application of gas, the red LED will light when a high gas alarm level is reached.

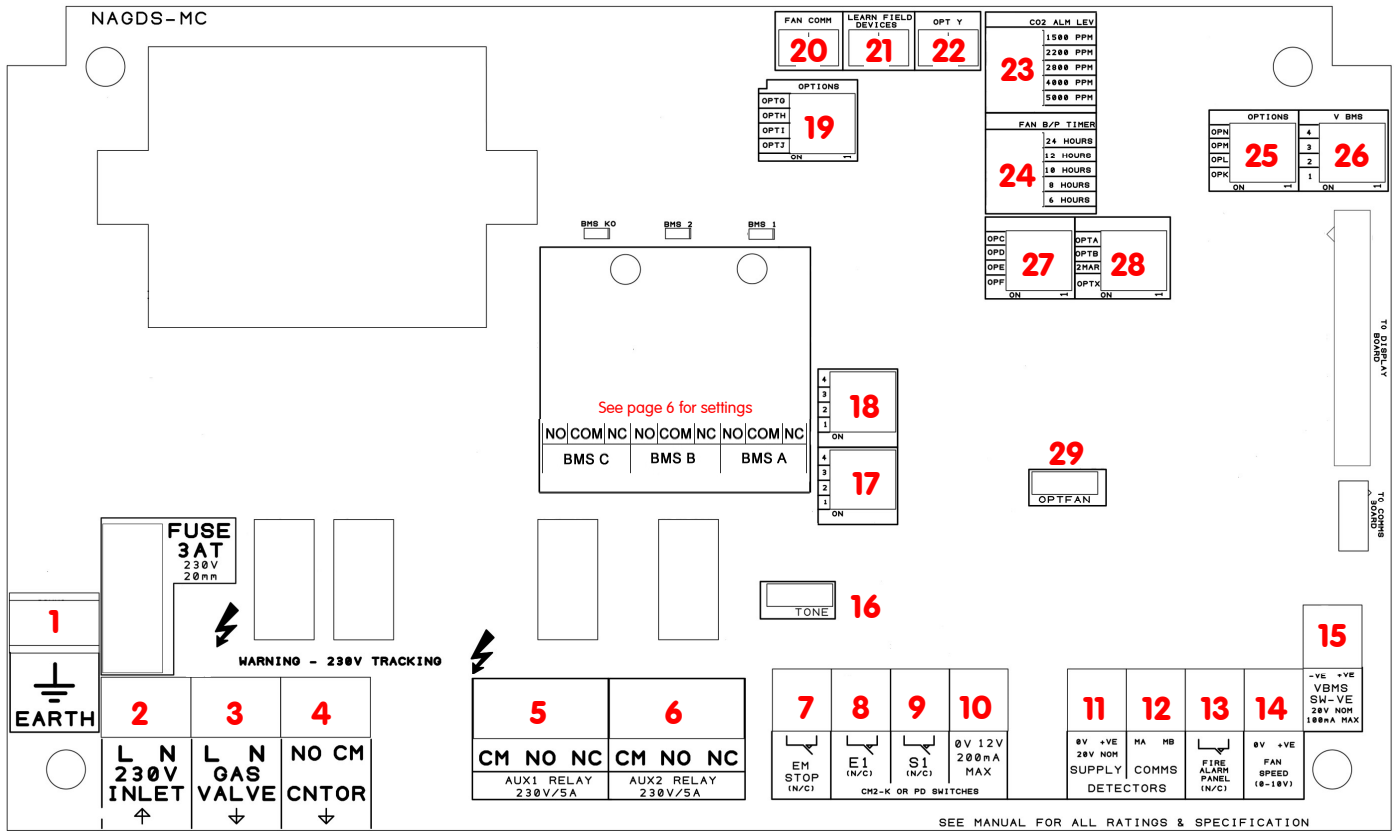

Connections to panel: marked on board

1. Earth connection terminals.
2. Live & Neutral 230 volts supply from 3amp switched fuse spur.
3. 230 volts out to gas solenoid valve.
4. To contactor for isolating socket electricity supply, or fan (optional).
5. Mains rated BMS relay set using switch **18**.
6. Mains rated BMS relay set using switch **17**.
7. Remote emergency stop and thermal links, SELV, connect in series multiple buttons (requires a N/C circuit).
8. Extract fan interlock for current monitor (CM2M-K) or PD switches.
9. Supply fan interlock for current monitor (CM2M-K) or PD switches.
10. 12 volt power for current monitor (CM2M-K).
11. Power connections for detectors, Methane, LPG, CO, CO2, Oxygen, Temperature.
12. Comms connections for detectors, Methane, LPG, CO, CO2, Oxygen, Temperature.
13. Fire alarm input signal (N/C contact required).
14. 0-10 volt output to fan speed controllers based on CO2 and temperature levels.
15. SELV Output for low power beacons/toners. Set using switch **26**.
16. Enable/Disable internal toner.
17. BMS relays settings for relays AUX 1 (**5**) and (**A**) See page 6.
18. BMS relays settings for relays AUX 2 (**6**) and (**B**) See page 6.
19. See page 7.
20. Fan comm button, enables commissioning of the gas supply without fans running.
21. Learn field device button, press once only when all detectors are connected and powered (verify with detectors button).
22. Lift Valve - will power open the gas valve (**2**) while the button is held down.
23. CO2 alarm level adjustment depending on application. Factory set for model & use.
24. Timer adjustment for fan commissioning, allows timed period for gas installation commissioning.
25. See page 7.
26. Setting for VBMS (**15**). See page 6.
27. See page 7.
28. See page 7.
29. OPTFAN Enable/Disable the front panel "FANS" LED (switch on to disable).

Basic connections

Earth Connections not shown

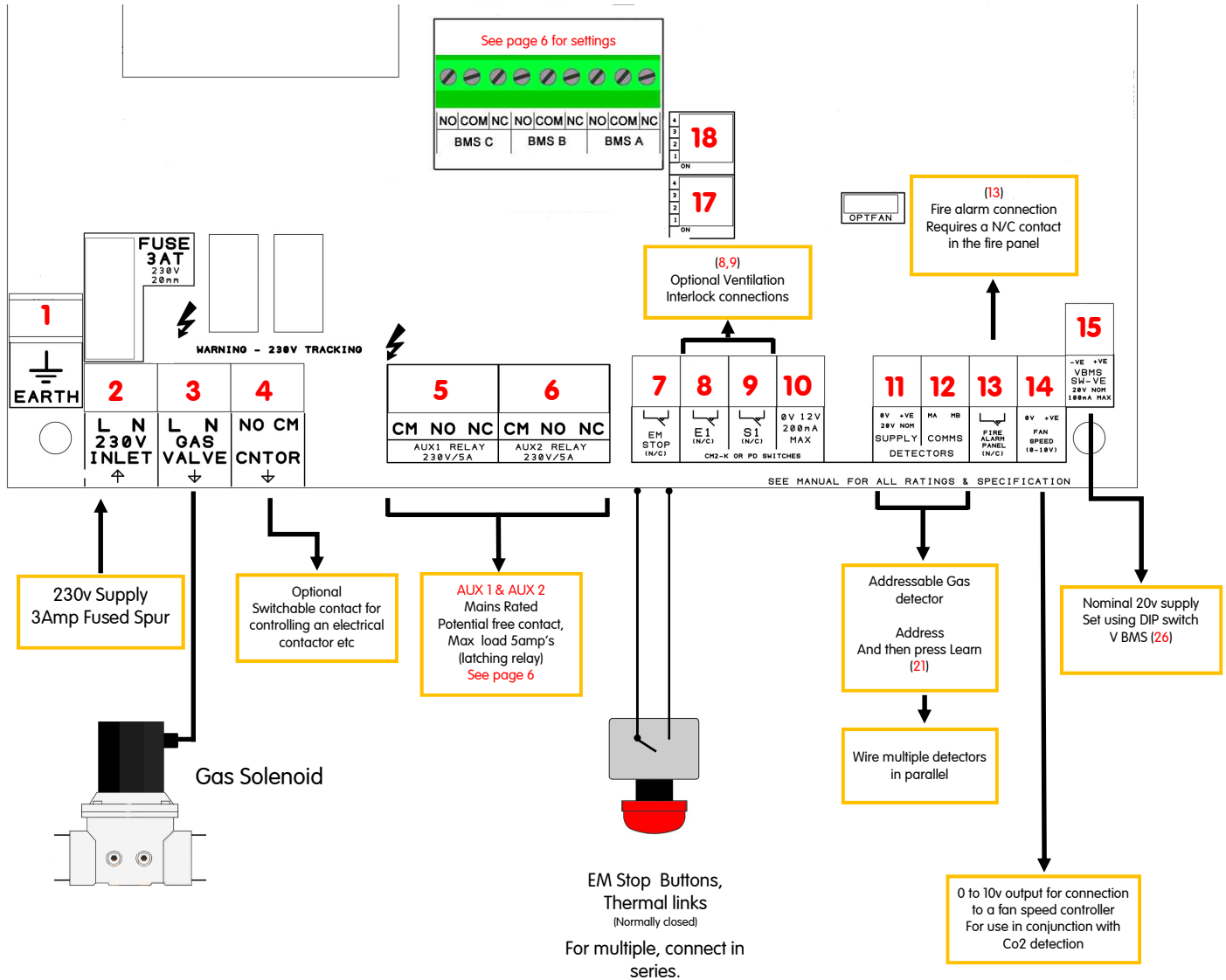

All current wiring regulations must be followed with reference to running low and mains voltage cables together. The maximum cable length between a detector and the control panel should not exceed 100 metres, whilst we would always recommend using screen cable if the distance between the main panel and the detectors is greater than 20metres a 1mm screened cable must be used on the +VE, 0v terminals

Gas detectors, require a **four core** screened Belden type security cable or 600v rated BMS cable (max cable length of 100meters.)

Remote emergency stops and thermal links require a two core screened cable.

Warranty will be void if Fire Protection Cable or cable over 1mm dia. is used on the SELV side.



AGDS-MC v2

Remote stop buttons

Single Stop Buttons

Remote stop buttons can be connected to the panel terminal marked as "EM STOP" (number 7).

The remote buttons must be wired as shown in order to provide a "closed contact" for the control panel.

If thermal links are to be installed these should be wired in series with the EM stop buttons

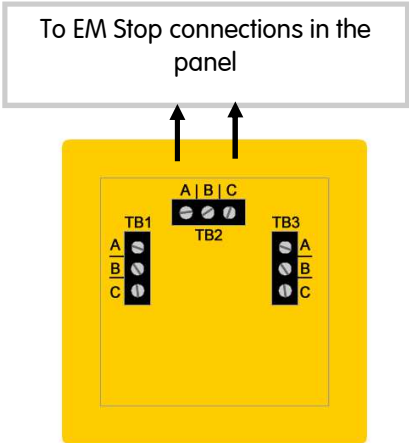

Use terminal TB2 A & C

Multiple Stop Buttons

Multiple stop buttons are wired in series.

If thermal links are to be installed these too should be wired in series with the EM stop buttons

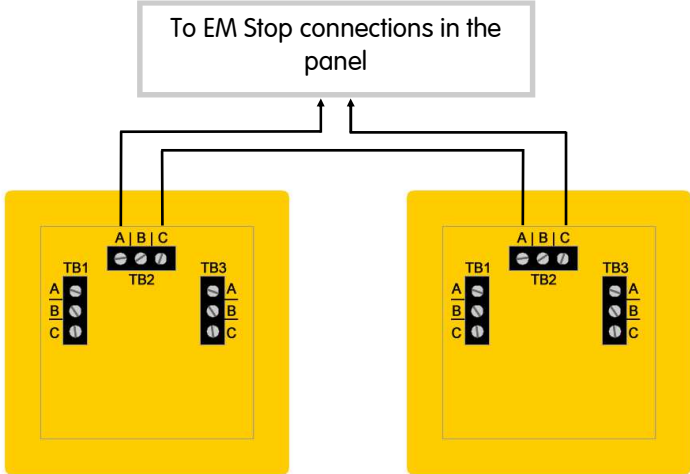

Use terminals TB2 A & C

Use terminals TB2 A & C

Resetting (indicator bar)

The stop buttons supplied by Medem are of a "Push Glass, key resettable" style, when activated a yellow indicator bar will show and the unit will require resetting using the key provided.

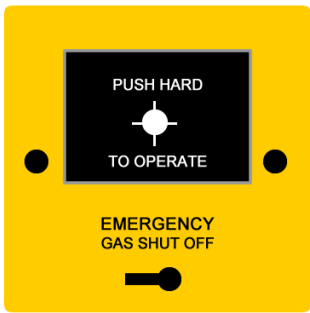

Normal

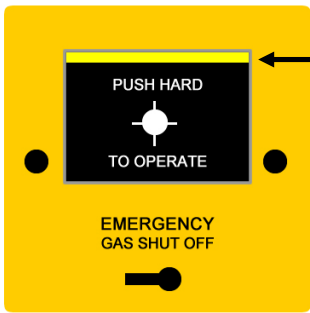

EM-Stop Activated

Indicator bar shows when pressed

BMS Relay Mains & SELV PCB

There are five relays on the system which can be used for connecting to a BMS or sounder/Beacon etc., these can be set for switching to various conditions using the table below. There are two mains rated (**AUX**) and three SELV (**BMS**)

Two Mains rated (230v 5amps)
 Three SELV relays. (48 volts 1 amp)

AUX 1 and **BMS A**: are set using switch **17**
AUX 2 and **BMS B**: are set using switch **18**

BMS C: Fixed condition, changes state on Gas Switch On/Off only.

Settable conditions via dip switches (One condition selectable for each pair of relays)

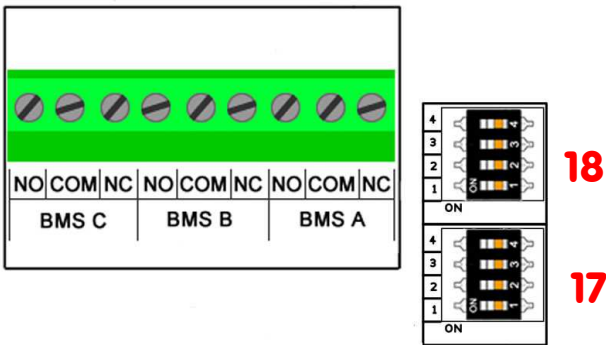

5			6		
CM	NO	NC	CM	NO	NC
AUX1 RELAY 230V/5A			AUX2 RELAY 230V/5A		

	1	2	3	4
Unused	OFF	OFF	OFF	OFF
Unused	ON	OFF	OFF	OFF
Unused	OFF	ON	OFF	OFF
Fan Fault - FF	ON	ON	OFF	OFF
EM Stop - ES	OFF	OFF	ON	OFF
Fire Panel Active -FA	ON	OFF	ON	OFF
High Alarm (Any State) - HA	OFF	ON	ON	OFF
Low Alarm (Any State) - LA	ON	ON	ON	OFF
Gas On State	OFF	OFF	OFF	ON
Detector Fault	ON	OFF	OFF	ON
Generic Fault (FF,ES,FA,HA)	OFF	ON	OFF	ON
Key Switch State	ON	ON	OFF	ON

15 & 26 V BMS

Terminal (15) VBMS is a nominal 20v output for use with external beacons, sounders etc. The output can be switched from 0 to +VE dependant on the setting of DIP switch (26) DIP switch options and setting are as per the table above

Option switch settings 19, 25, 27 & 28

There are various option switches available on the system for accommodating some of the more common situations

There always needs to be careful consideration to risk when changing any of the default settings, Medem (UK) Ltd would always recommend an onsite risk assessment be carried out before any changes are implemented.

28	OPT A	Spare
	OPT B	Auto restart on power failure and fire alarm (off by default)
	2MAR	Two minute delay to the auto restart - allows downstream appliances flame failure devices to close
	OPTX	Spare
27	OP C	Disables isolating gas on CO2 high alarm. CM & CO still isolate as normal
	OP D	
	OP E	Changes detector time to isolate from 5s to 45s for CM & CO
	OP F	Changes CO alarm levels from 20 & 30 PPM to 80 & 100PPM
19	OPT G	Fan run time using "FRUN" button
	OPT H	Spare
	OPT I	Allows BMS relays to indicate gas detector status when main "Gas On" switch is off
	OPT J	Spare
25	OP K	Spare
	OP L	Spare
	OP M	Spare
	OP N	Spare

Gas Detection

Gas Detectors

IMPORTANT - Gas Detectors should not be installed until all building, construction or painting work etc.. Is completed, as these works can effect the sensitivity and longevity of the detectors.



Ensure that the protective cover labels (**RED**) are removed only after the completion of all building work and the system has been commissioned by the Medem engineer.

The labels are required to be removed for the detectors to operate, but removal before the completion of works risks contaminating the sensor element.

The system is capable of operating a mix of up to 16 detectors (additional power pack may be required) of different types.

The detector types are:

- Carbon Monoxide.
- Carbon Dioxide.
- Combustible gases (Methane, Propane).
- Oxygen.

Detector location will vary dependant on the individual characteristics of the target gas that is being monitored for. See the gas detectors own instructions for more guidance.

Connection and addressing

When addressing gas detectors CO & CO₂ detectors must be numbered before combustible gas detectors.

Address Selector

Each detector must be set to its own address.

And then "learnt" using button (21)

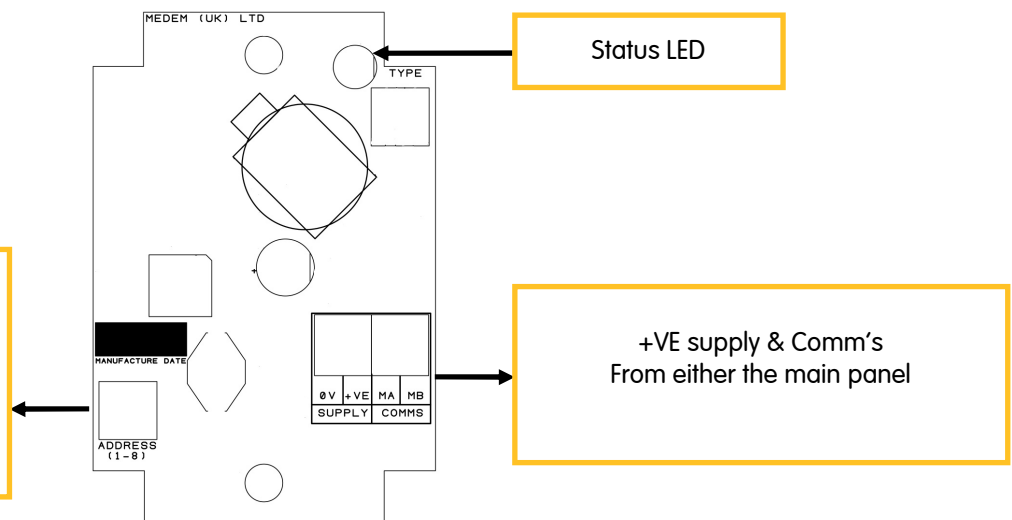

Status LED

+VE supply & Comm's
From either the main panel

All current wiring regulations must be followed with reference to running low and mains voltage cables together. The maximum cable length between a detector and the control panel should not exceed 100 metres, if the distance between the main panel and the detectors is greater than 20metres a 1mm screened cable must be used on the +VE, 0v terminals

Gas detectors, require a four core screened Belden type security cable or 600v rated BMS cable (max cable length of 100meters.)

Remote emergency stops and thermal links require a two core screened cable.

Warranty will be void if Fire Protection Cable or cable over 1mm dia. is used on the SELV side.

Detector Indications

Each detector has its own Bi-Colour LED which is used to indicate the status of that detector.

Not Lit:	No power/comm's. These are four wire units and all connections are required, check the polarity of both the power and the comm's (MA/MB) terminals are correct. Check the detector is address to the correct channel and the detector has been learnt using (21)
Flashing Green:	Detector is warming up, the detectors will flash green on power up for 90 seconds while the sensor elements stabilize. The system will ignore any detectors while flashing.
Solid Green:	Detector is powered and active.
Flashing Red:	Low level alarm. All detectors have both a low and high level alarm, low level alarms serve as a warning that an unsafe condition maybe building and gives chance to intervene before loss of gas service.
Solid Red	High level alarm. An unsafe level of the target gas have been reached and the system will isolate the gas supply. The cause of the alarm will require identifying and resolving before the gas supply can be re-established.

After installation a simple bump test can be performed by using an appropriate level test gas in order to check operation. Full testing and calibration checking takes place during a Medem commissioning.

Detector Location information

Detector location will vary dependant on the individual characteristics of the target gas that is being monitored for. The descriptions below describe the position for each detector after considering these characteristics.

For proper function care must be taken not to site a detector in a "dead space" or in the flow of any ventilation.

Natural Gas/Methane

Natural gas detectors should be mounted at high level on a wall approximately 150mm from the ceiling height and avoiding corners and potential dead air areas.

Natural gas detectors should not be mounted below the height of the top of a doorway for example. This is because as the gas is slightly lighter than air it will rise filling the room from the ceiling down and will spill through the top of a door opening into the next room. If the detectors are mounted below this height then it will take longer the gas to reach the detector.

LPG /Propane

LPG gas is heavier than air so detectors need to be mounted at low level 100mm from the floor, consideration should be given to any potential mopping or wet floor height.

Carbon Monoxide

Carbon Monoxide is similarly weighted to air so detectors should be mounted between 1 to 2 meters from the floor.

Carbon Dioxide

Carbon Dioxide detectors should be installed so they monitor the general level of CO2 within the area. They should be mounted above standing head height and between 1m and 3m from the potential source. Care should be taken so they are not located close to the edge of a canopy or in direct flow of the supply or extract ventilation.

For additional information or guidance on site specific requirements please don't hesitate to contact us.

Medem (UK) Limited
Project House
19 Dallimore Road
Manchester
M23 9NX

Tel: (0) 161 233 0600

Fax: (0) 161 233 0601

Web: www.medem.co.uk

E-mail: sales@medem.co.uk

Medem UK Warranty Terms & Conditions

1. The warranty is a parts warranty and Medem UK Ltd will not cover or accept any labour or other expenses that may be incurred in the process of changing faulty product.
2. All panels and sender units are covered by a five year warranty.
3. Gas detector units and other remote detectors carry a two year warranty. Installation of the detectors should not be undertaken until all building and construction work is completed.
4. Gas solenoid valves carry the original manufacturers warranty, though as the supplier Medem UK will exchange faulty valves for return to the manufacturer.
5. Where a Medem UK engineer (or another company appointed by Medem UK) commission and installed system then that system will carry a ten year warranty. This applies to the main panel and the sender unit. At the time of commissioning a security label with a serial number will be attached to the main panel box. photographs and a comprehensive record of the installation will be held by Medem UK.
6. Where a warranty claim is made then, where appropriate, a written order to attend site must be provided to Medem UK A cost for labour and travel to site will be prepared as a quote. The cost must be included in the order.
7. Where it is found that the installation and/or the quality of workmanship has contributed to or wholly caused the failure of the product then we reserve the right to charge the whole or a proportion of the cost of the faulty item.

It is essential that the installation is carried out in the order given below to ensure the correct operation of the system.

First read the system description sheet before following the instructions below

1. Connect the Control valve twin & earth to the marked terminals.
2. Connect BMS, beacons, sounders etc to the relay outputs.
3. Connect any additional EM stop buttons and thermal links in series to the terminals marked "em stop"
4. Each detector has a blue rotary selector switch and each switch should be set to a different number or letter starting with "0". Then connect the gas detectors to terminals marked "detectors" (11,12) on the panel. Detectors can be wired "Daisy chain".
5. Connect the 3 amp fused spur 240 volt supply to marked terminals (2).
6. Once power is connected to the panel the detectors will flash the green LEDs for 90 seconds after which the LEDs will be on continuously.
7. Press the "learn field button" this is on the main circuit board (no 21). Pressing this once allows the panel to learn how many and which type of detectors are fitted.
8. Press the "Detectors" button on the front panel and check on the display that all the detectors have been recognised by the system. A recognised detector will appear as "CMOX", "CDOX", "CMBS" or "OXYG" with the detector reading now to it. Use the UP and Down buttons to page through the detector listing to check all addresses. Note that a detector set at 0 appears as 1 on the LCD and a detector set as 1 appears as 2 on the LCD etc.
9. At this point turn the on/off switch to the on position and panel will open the gas valve.
10. A functionality test of the detectors can be carried out by applying a small amount of target gas to the detectors. The detector LED will turn red and the panel will alarm and close the valve.

Notes.

It is recommended that all systems are commissioned after installation by Medem UK. This will extend the warranty period from 5 years to 10 years and ensure the system is working as designed.
Please see warranty conditions that came with the main panel

Please do not hesitate to call for advice on the following numbers:

0161 233 0600 office hours

Or out of hours call: 07843 355163 UK only