



## Installation Instructions

The AGDS-V is a four channel gas detection system. Up to four low voltage detectors can be connected for the detection of natural gas, LPG, carbon monoxide, carbon dioxide and oxygen depletion.

In the event of a high alarm from one of the detectors, the system will isolate a connected control valve. Low alarm indication is also given.

It is designed for use primarily in boiler house.

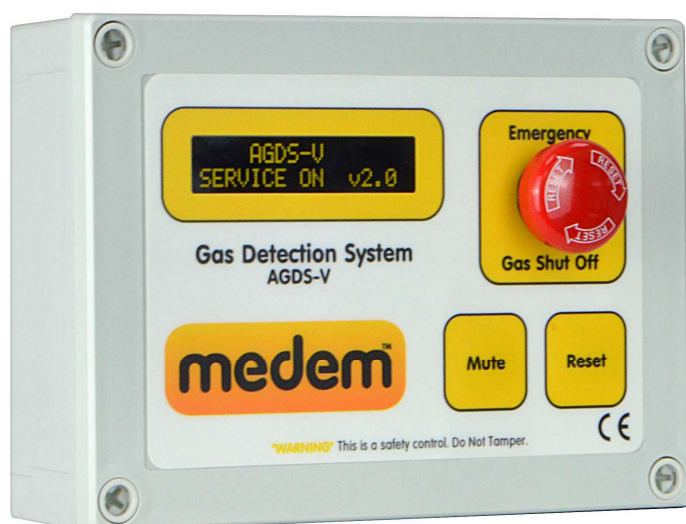

- Gas Detection (up to 4 detectors )
- Natural gas, LPG, carbon monoxide, carbon dioxide and oxygen depletion
- 2 x BMS relays (selectable alarm status inc. high alarm)
- 5 year warranty - 10 years when commissioned

### AGDS-V features

Before commencing installation please familiarise yourself to the equipment by reading the comprehensive installation instructions. If in doubt then please call 0161 233 0600. Out of hours please call 07894 684080 or 07843 355163.

**It is a statutory requirement that this safety system is installed and commissioned to the satisfaction of the manufacturer.**

A commissioning certificate must be issued to the end user along with instructions for the operation of the equipment.

As the Manufacturer Medem UK should commission this safety system whereupon a commissioning report will be forwarded to the installing agent who should provide a copy to the end user.

At the point of our commissioning an individual serial number will be attached to the system along with a 24 help line number. Photos and all relevant information for the installation will then be stored on the Medem site database to be accessed in the event of a call on the 24 hour help line. The warranty period for the panel and sender unit will then be extended to Ten years.

The AGDS-V is a gas detection system designed to monitor the atmosphere for target gases. The system comprises of a mains powered panel capable of operating up to four Medem sensors

The sensors are pre-calibrated by Medem (UK) Ltd such that they only require to be connected to the panel and functionally tested.

In the event of a high alarm from one of the sensors the system will isolate the gas supply by closing a connected electric control valve. Emergency stop buttons and Thermal Links can be fitted and a fire alarm can close the gas valve when connected to the panel.

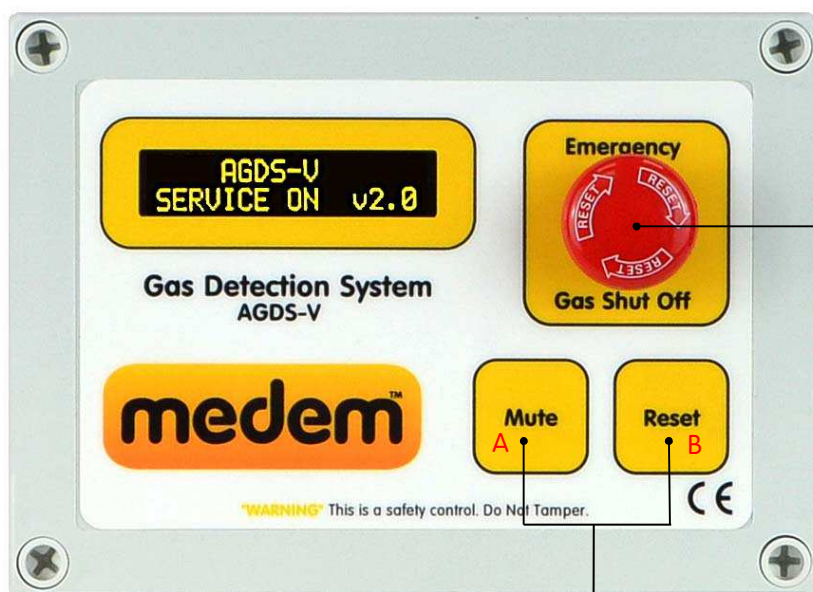

**Emergency Stop.** To isolate the gas valve in the event of an emergency

**A** Mute button, to mute the internal tone

**B** Reset button, for resetting and opening the valve after an alert/alarm condition.

### Control Panel

The front of the panel has the following controls and indications:

- Emergency stop button.
- Mute button for the internal toner.
- Reset button for clearing an alert

OLED display:

For displaying system status during both installation and normal use, also for displaying diagnostics

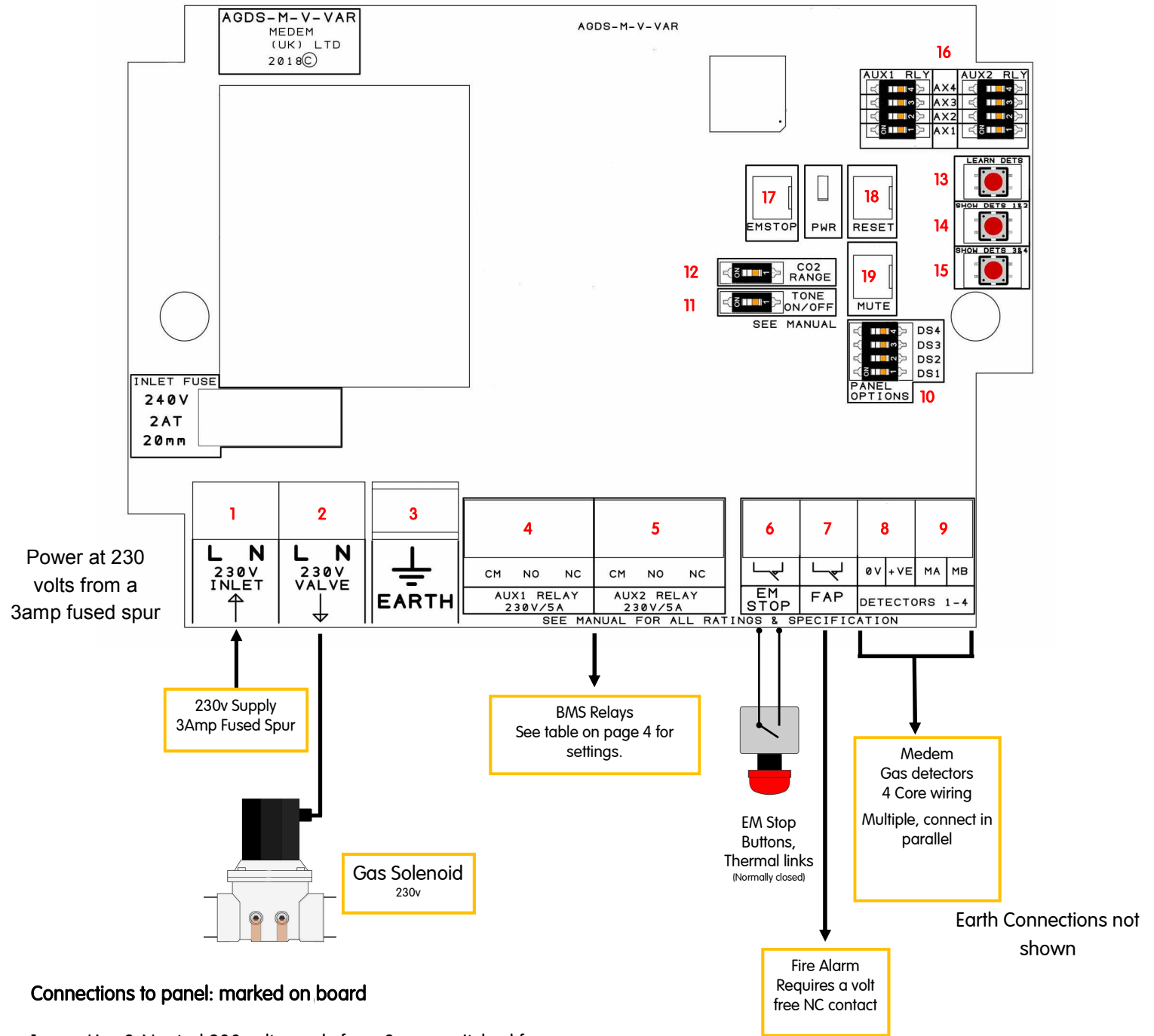

**Connections to panel: marked on board**

1. Live & Neutral 230 volt supply from 3amp switched fuse spur
2. 230 volts out to gas solenoid valve (required)
3. Earth connection terminals
4. AUX 1 BMS Relay
5. AUX 2 BMS Relay
6. Remote emergency stop and thermal links, SELV, connect in series multiple buttons (requires a N/C circuit)
7. Fire Alarm Panel connection, (requires N/C, volt free contact in the Fire Panel)
8. Power connections for detectors, Methane, LPG, CO, CO2, Oxygen, Temperature
9. Comms connections for detectors, Methane, LPG, CO, CO2, Oxygen, Temperature
10. Panel Mode switches (factory set, do not alter)
11. Internal tone on/off
12. Spare
13. Learn field device button, press once only when all detectors are connected and powered.
14. Display detector information 1 & 2 on screen
15. Display detector information 3 & 4 on screen
16. BMS Relay setting (see page 4 for details)

### 4, 5 & 16. BMS Relays and setting switch

There are two mains rated relays **4 & 5**, for connection to a BMS or Sounder/Beacon. Each relay is able to be set to report one of the status's in the table below.  
 Max switching 230 volts 5amp's

**16**

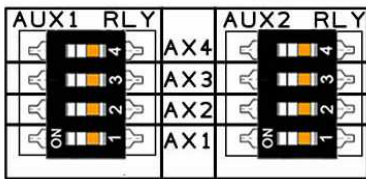

Status	AX1	AX2	AX3	AX4
EM Stop - ES	OFF	OFF	ON	OFF
Fire Panel Active -FA	ON	OFF	ON	OFF
High Alarm - HA	OFF	ON	ON	OFF
Low Alarm - LA	ON	ON	ON	OFF
Gas On/Off	OFF	OFF	OFF	ON
Detector Fault - DF	ON	OFF	OFF	ON
Generic Fault (ES, FA, HA, LA, DF)	OFF	ON	OFF	ON

### 13, 14 & 15 Learn and Display Detectors

**13**

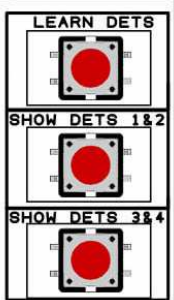

**Learn Dets.**

Any gas detectors connected to the system will require "learning". First ensure all detectors are set to a unique ID address using the selector switch on the detectors themselves (address's 1 to 4). Having addressed each detector, press the learn Dets button (13), the system will scan and store any connected detectors.

**14**

**Shows Dets 1&2, 3&4.**

To verify that all detectors have been successfully learnt use the Show Dets buttons 14/15 to verify the detectors are connected correctly.

**15**

Notes.

It is recommended that all systems are commissioned after installation by Medem UK. This will extend the warranty period from 5 years to 10 years and ensure the system is working as designed.  
 Please see warranty conditions that came with the main panel

### Gas Detection

#### Gas Detectors

**IMPORTANT** - Gas Detectors should not be installed until all building, construction or painting work etc.. Is completed, as these works can effect the sensitivity and longevity of the detectors.



Ensure that the protective cover labels (**RED**) are removed only after the completion of all building work and the system has been commissioned by the Medem engineer.

The labels are required to be removed for the detectors to operate, but removal before the completion of works risks contaminating the sensor element.

The system is capable of operating a mix of up to 4 detectors of different types.

The detector types are:

- Carbon Dioxide.
- Carbon Monoxide.
- Combustible gases (Methane, Propane).
- Oxygen depletion.

Detector location will vary dependant on the individual characteristics of the target gas that is being monitored for. See the gas detectors own instructions for more guidance.

### Connection and addressing

When addressing gas detectors CO & CO2 detectors must be numbered before natural gas detectors.

**Address Selector**  
Each detector must be set to its own address 1-4 and then "learnt" using button (13, see page 4)

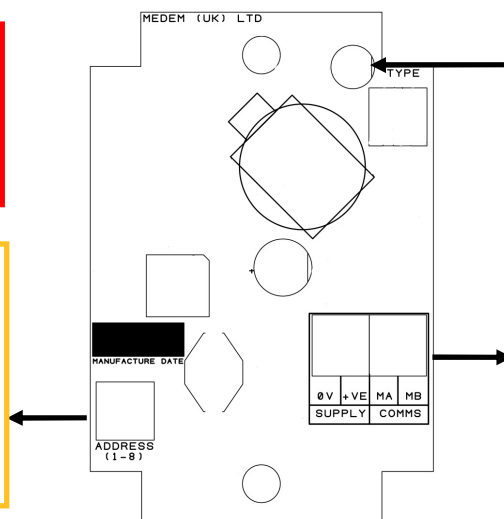

Status LED

+VE supply & Comm's  
From either the main panel or an extender.  
Detectors are wired in parallel and can be connected to one another daisy chain

All current wiring regulations must be followed with reference to running low and mains voltage cables together.

The maximum cable length between a detector and the control panel should not exceed 100 metres, if the distance between the main panel and the detectors is greater than 20metres a 1mm screened cable must be used on the +VE, 0v terminals

Gas detectors, require a four core screened Belden type security cable or 600v rated BMS cable (max cable length of 100meters.)

Remote emergency stops and thermal links require a two core screened cable.

Warranty will be void if Fire Protection Cable or cable over 1mm dia. is used on the SELV side.

## Detector Indications

Each detector has its own Bi-Colour LED which is used to indicate the status of that detector.

Not Lit:	No power/comm's. These are four wire units and all connections are required, check the polarity of both the power and the comm's (MA/MB) terminals are correct.
Flashing Green:	Detector is warming up, the detectors will flash green on power up for 90 seconds while the sensor elements stabilize. The system will ignore any detectors while flashing.
Solid Green:	Detector is powered and active. <b>Note:</b> The detectors will still require correctly addressing (using the address selector pot) and learning by the system using button (13, see page 4).
Flashing Red:	Low level alarm. All detectors have both a low and high level alarm, low level alarms serve as a warning that an unsafe condition maybe building and gives chance to intervene before loss of gas service.
Solid Red	High level alarm. An unsafe level of the target gas have been reached and the system will isolate the gas supply. The cause of the alarm will require identifying and resolving before the gas supply can be re-established.

After installation a simple bump test can be performed by using an appropriate level test gas in order to check operation. Full testing and calibration checking takes place during a Medem commissioning.

## Detector Location

Detector location will vary dependant on the individual characteristics of the target gas that is being monitored for. The descriptions below describe the position for each detector after considering these characteristics.

For proper function care must be taken not to site a detector in a "dead space" or in the flow of any ventilation.

### **Natural Gas/Methane**

Natural gas detectors should be mounted at high level on a wall approximately 150mm from the ceiling height and avoiding corners and potential dead air areas.

Natural gas detectors should not be mounted below the height of the top of a doorway for example. This is because as the gas is slightly lighter than air it will rise filling the room from the ceiling down and will spill through the top of a door opening into the next room. If the detectors are mounted below this height then it will take longer the gas to reach the detector.

### **LPG /Propane**

LPG gas is heavier than air so detectors need to be mounted at low level 100mm from the floor, consideration should be given to any potential mopping or wet floor height.

### **Carbon Monoxide**

Carbon Monoxide is similarly weighted to air so detectors should be mounted between 1 to 2 meters from the floor.

### **Carbon Dioxide**

Carbon Dioxide detectors should be installed so they monitor the general level of CO<sub>2</sub> within the area. They should be mounted above standing head height and between 1m and 3m from the potential source. Care should be taken so they are not located close to the edge of a canopy or in direct flow of the supply or extract ventilation.

*For additional information or guidance on site specific requirements please don't hesitate to contact us.*

### Single Stop Buttons

Remote stop buttons can be connected to the panel terminal marked as "EM STOP" (number 6).

The remote buttons must be wired as shown in order to provide a "closed contact" for the control panel.

**If thermal links are to be installed these should be wired in series with the EM stop buttons**

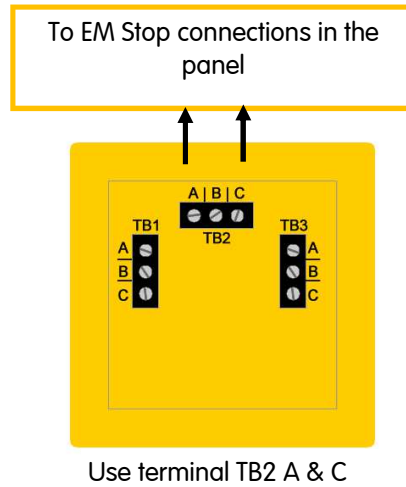

### Multiple Stop Buttons

Multiple stop buttons are wired in series.

If thermal links are to be installed these too should be wired in series with the EM stop buttons

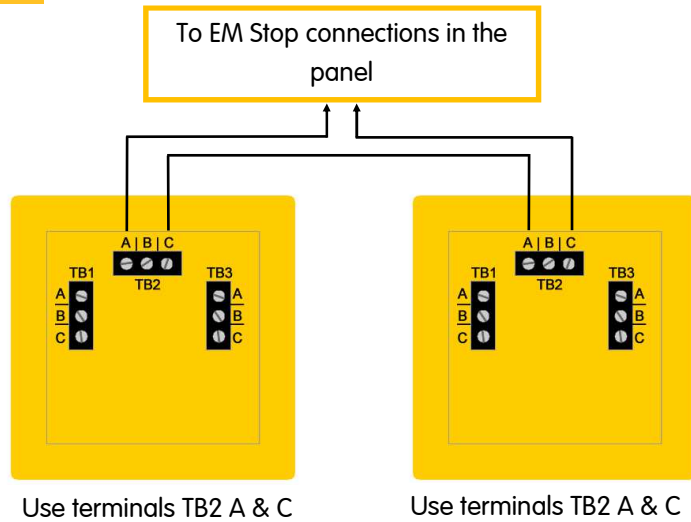

### Resetting (indicator bar)

The stop buttons supplied by Medem are of a "Push Glass, key resettable" style, when activated a yellow indicator bar will show and the unit will require resetting using the key provided.

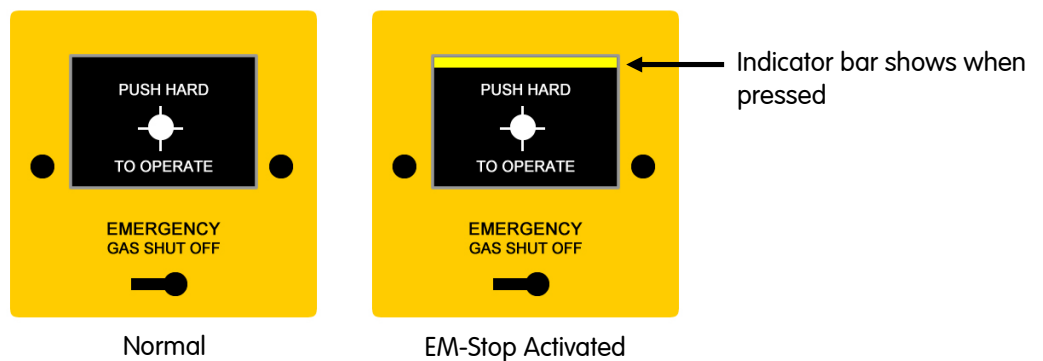



Medem (UK) Limited  
Project House  
19 Dallimore Road  
Manchester  
M23 9NX

Tel: (0) 161 233 0600  
Fax: (0) 161 233 0601

Web: [www.medem.co.uk](http://www.medem.co.uk)  
E-mail: [sales@medem.co.uk](mailto:sales@medem.co.uk)

## Medem UK Warranty Terms & Conditions

1. The warranty is a parts warranty and Medem UK Ltd will not cover or accept any labour or other expenses that may be incurred in the process of changing faulty product.
2. All panels and sender units are covered by a five year warranty.
3. Gas detector units and other remote detectors carry a two year warranty. Installation of the detectors should not be undertaken until all building and construction work is completed.
4. Gas solenoid valves carry the original manufacturers warranty, though as the supplier Medem UK will exchange faulty valves for return to the manufacturer.
5. Where a Medem UK engineer (or another company appointed by Medem UK) commission and installed system then that system will carry a ten year warranty. This applies to the main panel and the sender unit. At the time of commissioning a security label with a serial number will be attached to the main panel box. photographs and a comprehensive record of the installation will be held by Medem UK.
6. Where a warranty claim is made then, where appropriate, a written order to attend site must be provided to Medem UK A cost for labour and travel to site will be prepared as a quote. The cost must be included in the order.
7. Where it is found that the installation and/or the quality of workmanship has contributed to or wholly caused the failure of the product then we reserve the right to charge the whole or a proportion of the cost of the faulty item.



It is essential that the installation of the AGDS-V is carried out in the order given below to ensure the correct operation of the system.

First read the system description sheet before following the instructions below

1. Connect the gas valve to the marked terminals "valve".
2. Connect any additional EM stop buttons or thermal links in series to the terminals marked "EM stop" (6)
3. Each detector/device has a rotary address switch, each switch should be set to a different number 1-4. Then connect the gas detectors to terminals marked "detectors" on the panel. Detectors are wired in parallel. "Daisy chain" (08 & 09 )
4. Connect fire alarm, ensure volt free n/c (7)
5. Ensure any BMS connections are made to the relays (4 & 5)
6. Connect the 3 amp fused spur 240 volt supply to marked terminals.
7. Once power is connected to the panel the detectors will flash the green LEDs for 90 seconds after which the LEDs will be on continuously.
8. Press the "learn field button" (13) this is on the main circuit board on the right hand side, just over half way up the board pressing this once allows the panel to learn how many and which type of detectors are fitted.
9. Press and keep pressed the "display detectors 1-2 or 3-4" button whilst checking on the display that all the detectors have been recognised by the panel.
10. At this point press the "reset" button, the panel will open the gas valve.

**Please do not hesitate to call for advice on the following number:  
0161 233 0600 office hours**

## messages

In the event of any alert the system will always give a reason on screen as to the cause.

Common messages you may receive are shown below with further explanation.

If you require any help or if anything is unclear then please contact technical support on 0161 233 0600

### **Detector fault XX**

The system believes it has lost connection to a detector on address XX, verify detector addresses and press the "learn button" (23). Verify all connected detectors are being registered by pressing "blind button B" (see page 2). If you have no detectors connected to the system pressing the learn button will clear the error message.

### **Emergency stop button pressed.**

The system has an panel mounted emergency stop and connection inside for remote buttons. First check the panel button (once pressed some require resetting by twisting and releasing). Clear the message by turning the main system switch off and then back on, if the message remains check any remote buttons and their connections. The terminal for the remote buttons requires a volt free normally closed contact, ensure all remote stop buttons, thermal links any another connected systems (BMS/Fire panels) are reset and the contacts are closed.