

medem SafeAir CM (GP)

Installation Instructions

The SafeAir CM (GP) is a ventilation interlock and gas pressure proving system with gas detection.

The system will ensure that any mechanical ventilation connected (supply and/or extract) is running before the gas can be used, when installed with gas sensors it will also monitor the atmosphere for CO and/or CO₂. It will then continually monitor for fan operation.

The system will also ensure there are no gas leaks downstream of the control valve at switch on by way of a downstream integrity check, it continually checks that the incoming gas pressure is sufficient.



- Gas Pressure proving.
- Gas Detection .(up to 4 detectors)
- Built in Fan Current Monitor for Fan interlocking.
- 5 year warranty - 10 years when commissioned

SafeAir CM (GP) features

Before commencing installation please familiarise yourself to the equipment by reading the comprehensive installation instructions. If in doubt then please call 0161 233 0600. Out of hours please call 07894 684080 or 07843 355163.

It is a statutory requirement that this safety system is installed and commissioned to the satisfaction of the manufacturer.

A commissioning certificate must be issued to the end user along with instructions for the operation of the equipment.

As the Manufacturer Medem UK should commission this safety system whereupon a commissioning report will be forwarded to the installing agent who should provide a copy to the end user.

At the point of our commissioning an individual serial number will be attached to the system along with a 24 help line number. Photos and all relevant information for the installation will then be stored on the Medem site database to be accessed in the event of a call on the 24 hour help line. The warranty period for the panel and sender unit will then be extended to Ten years.

Gas Pressure Proving and Ventilation Interlock System For Kitchens

The **SafeAir CM (GP)** is a Ventilation Interlock and Gas Pressure Proving system with inbuilt two channel current monitor. The system will ensure that any mechanical ventilation connected (supply or extract) is running before the gas can be used. When installed with Medem gas detectors it will also monitor the atmosphere for CO (Carbon Monoxide) and/or CO₂ (Carbon Dioxide).

The system will also ensure there are no gas leaks downstream of the control valve at switch on by way of a downstream integrity check. It continually checks that the incoming gas pressure is sufficient.

The system comprises of a mains powered panel capable of operating up to four sensors and internal two channel current monitor for interlocking the mechanical ventilation with a monitoring range of 30 mAmps to 24 Amps. The ventilation can also be interlocked by mechanical air flow switches (DP) if required.

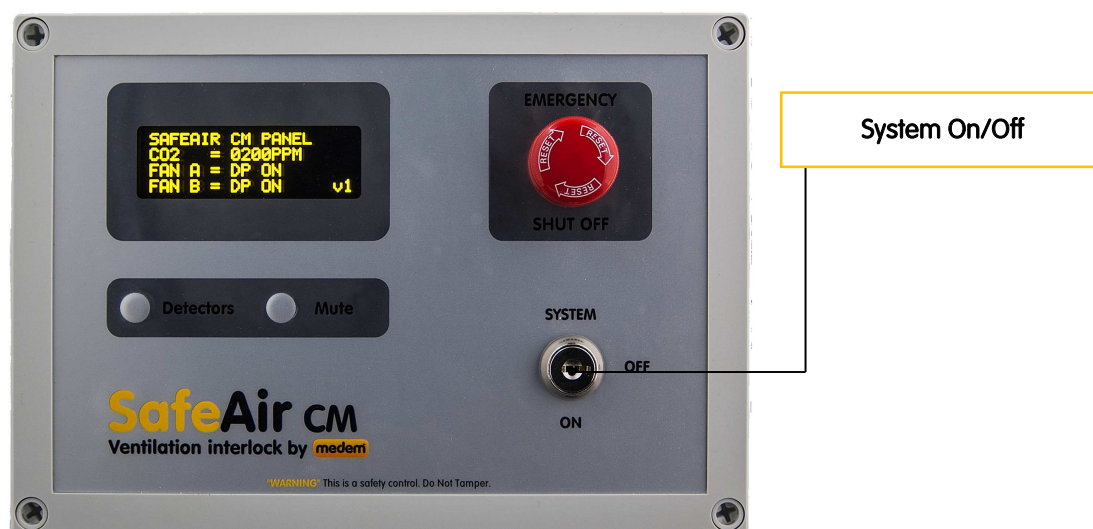

Control Panel

The front of the panel has the following controls and indications:

- Emergency stop button.
- System On/Off switch.
- Detectors button - For viewing detector status
- Mute.

LCD display:

For displaying system status during both installation and normal use, also for displaying diagnostics

Pressure Sender Unit

Pressure sender unit transmits pressure information back to the main panel in order for it to perform its integrity test. It is not optional and must be connected, **the system will not work without it.**

It is mounted to the gas solenoid valve inlet and outlet test ports using 8mm OD copper pipe. Use the appropriate Medem fitting kit to fit the control valve size (see page 7,8).

Incoming gas pressure: Min = 12 mbar, Max = 70mb.

The pressure sender is connected to the control panel with low voltage two core cable using the terminal marked A & B.

NOTE: This is low voltage and should be segregated from mains wiring.

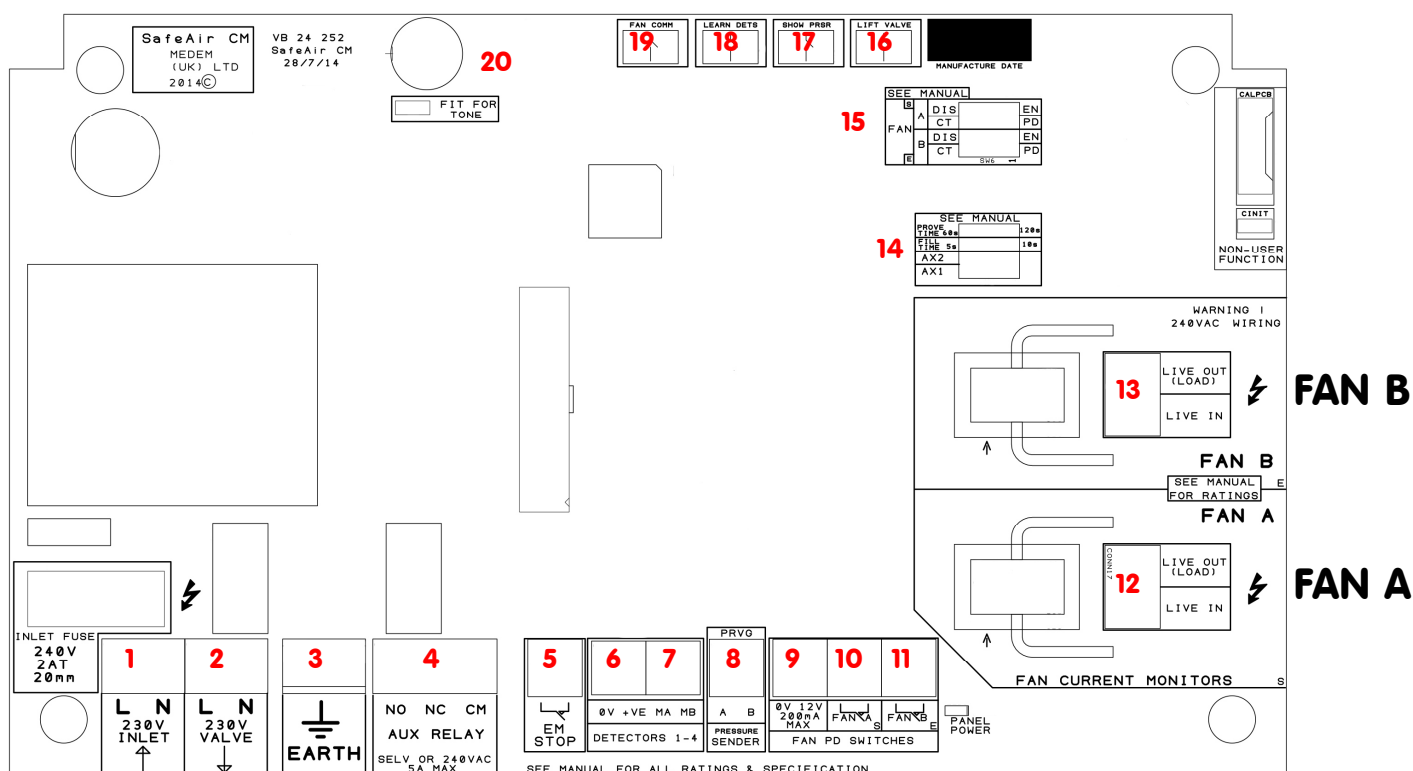

Connections to panel: marked on board.

1. Live & Neutral 230 volts supply from 3amp switched fuse spur
2. 230 volts out to gas solenoid valve
3. Earth connection terminals
4. BMS to indicate, high alarm, gas on, EM stop, low alarm. (Using No14 AX1 & 2)
 - 00 = Gas On
 - 01 = Fan Fault
 - 10 = EM Stop & High Alarm
 - 11 = Unused
5. Remote emergency stop buttons SELV, connect in series multiple buttons (requires a N/C circuit)
6. Power connections for detectors, Methane, LPG, CO, CO2, Oxygen, Temperature
7. Comms connections for detectors, Methane, LPG, CO, CO2, Oxygen, Temperature
8. Pressure sender unit SELV and comm's both through "A" & "B" terminals (2 wire) MUST BE FITTED
9. 12 volt power
10. Fan A interlock for PD switches.
11. Fan B interlock for PD switches.
12. Fan A current monitor (CT) connection.
13. Fan B current monitor (CT) connection.
14. Fill & prove time for gas pressure proving & AUX relay settings (see No4).
15. Set Fan A to use either PD switch (No10) or Current Monitor (CT) (No12)
16. Lift valve button, opens the gas valve only whilst the button is continuously pressed, for commissioning purposes.
17. Display gas pressures on the LCD screen
18. Learn detectors button, press once only when all detectors are connected and powered. Also "learn Trip Current" when pressed in conjunction with "No.19 Fan Comm" see page 4 for more details
19. Fan comm button: Displays the "Fan Current Trip level" this is the minimum fan current draw allowed before the system will indicate that the fans aren't running. (Default 35mA).

Gas Detection

Gas Detectors

IMPORTANT - Gas Detectors should not be installed until all building, construction or painting work etc.. Is completed, as these works can effect the sensitivity and longevity of the detectors.



Ensure that the protective cover labels (**RED**) are removed only after the completion of all building work and the system has been commissioned by the Medem engineer.

The labels are required to be removed for the detectors to operate, but removal before the completion of works risks contaminating the sensor element.

The system is capable of operating a mix of up to 4 detectors of different types.

Detector Alarm levels

Type	Pre-Alarm	High Alarm
CO:	80ppm	100ppm
CO2:	1800ppm	2800ppm

Pre-alarm will display a warning message and tone (3beeps) every 10mins.

High-alarm will display a warning message, tone every one second and isolate the gas valve after 60seconds.

Detector location will vary dependant on the individual characteristics of the target gas that is being monitored for. See the gas detectors own instructions for more guidance.

Connection and addressing

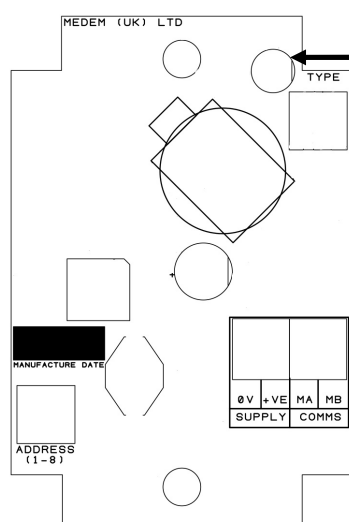

Status LED

Address Selector

Each detector must be set to its own address (1-4) and then "learnt" using button 18 (see page 3)

+VE supply & Comm's
From either the main panel or an extender.

Detectors are wired in parallel and can be connected to one another daisy chain

All current wiring regulations must be followed with reference to running low and mains voltage cables together.

The maximum cable length between a detector and the control panel should not exceed 100 metres, if the distance between the main panel and the detectors is greater than 20metres a 1mm screened cable must be used on the +VE, 0v terminals

Gas detectors, require a four core screened Belden type security cable or 600v rated BMS cable (max cable length of 100meters.)

Pressure sender unit, remote emergency stops, require a two core screened cable.

Warranty will be void if Fire Protection Cable or cable over 1mm dia. is used on the SELV side.

Detector Indications

Each detector has its own Bi-Colour LED which is used to indicate the status of that detector.

Not Lit:	No power/comm's. These are four wire units and all connections are required, check the polarity of both the power and the comm's (MA/MB) terminals are correct.
Flashing Green:	Detector is warming up, the detectors will flash green on power up for 90 seconds while the sensor elements stabilize. The system will ignore any detectors while flashing.
Solid Green:	Detector is powered and active. Note: The detectors will still require correctly addressing (using the address selector pot) and learning by the system using button 16 (see page 3).
Flashing Red:	Low level alarm. All detectors have both a low and high level alarm, low level alarms serve as a warning that an unsafe condition may be building and gives chance to intervene before loss of gas service.
Solid Red	High level alarm. An unsafe level of the target gas has been reached and the system will isolate the gas supply. The cause of the alarm will require identifying and resolving before the gas supply can be re-established.

After installation a simple bump test can be performed by using an appropriate level test gas in order to check operation. Full testing and calibration checking takes place during a Medem commissioning.

Detector Location

Detector location will vary dependant on the individual characteristics of the target gas that is being monitored for. The descriptions below describe the position for each detector after considering these characteristics.

For proper function care must be taken not to site a detector in a "dead space" or in the flow of any ventilation.

Natural Gas/Methane

Natural gas detectors should be mounted at high level on a wall approximately 150mm from the ceiling height and avoiding corners and potential dead air areas.

Natural gas detectors should not be mounted below the height of the top of a doorway for example. This is because as the gas is slightly lighter than air it will rise filling the room from the ceiling down and will spill through the top of a door opening into the next room. If the detectors are mounted below this height then it will take longer for the gas to reach the detector.

LPG /Propane

LPG gas is heavier than air so detectors need to be mounted at low level 100mm from the floor, consideration should be given to any potential mopping or wet floor height.

Carbon Monoxide

Carbon Monoxide is similarly weighted to air so detectors should be mounted between 1 to 2 meters from the floor.

Carbon Dioxide

Carbon Dioxide detectors should be installed so they monitor the general level of CO2 within the area. They should be mounted above standing head height and between 1m and 3m from the potential source. Care should be taken so they are not located close to the edge of a canopy or in direct flow of the supply or extract ventilation.

For additional information or guidance on site specific requirements please don't hesitate to contact us.

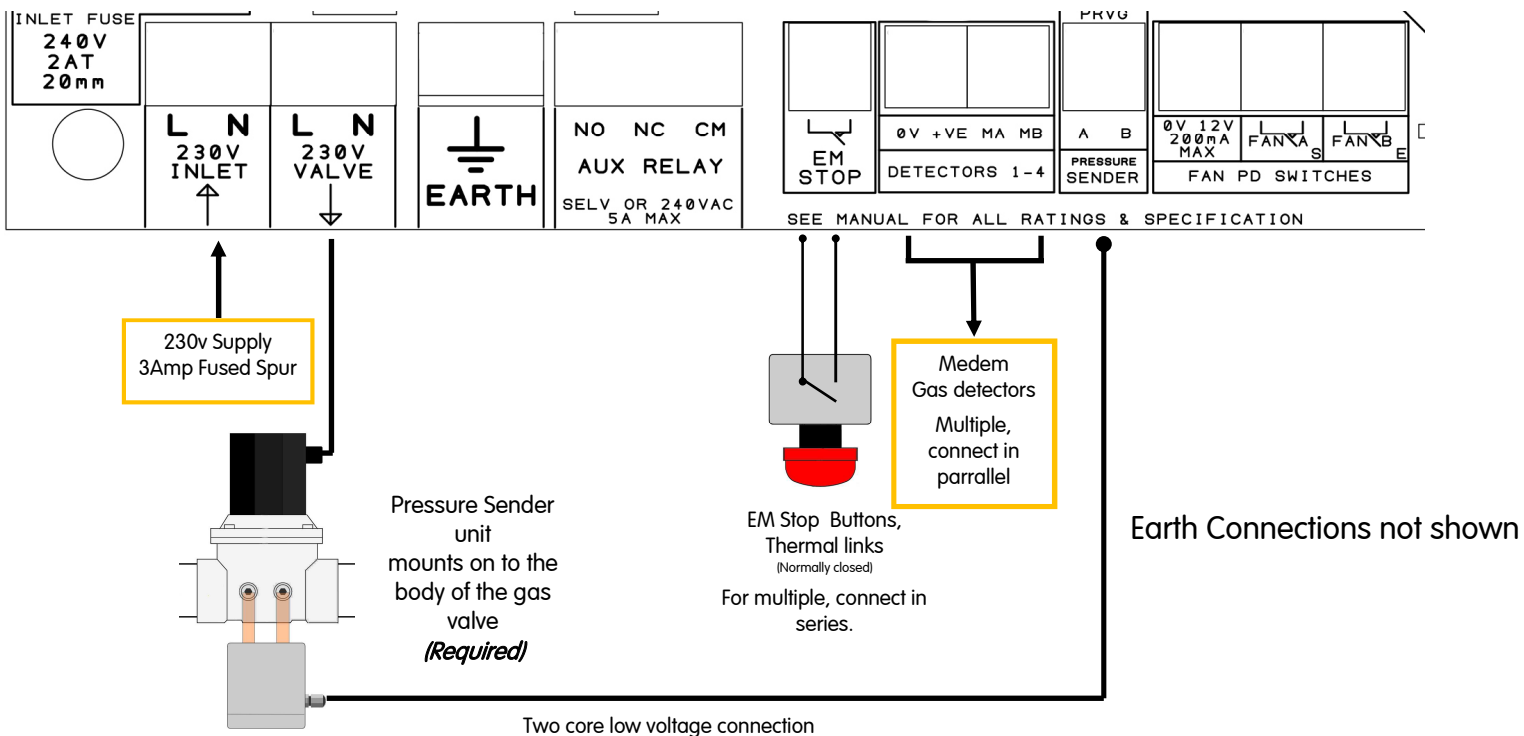

Set a minimum fan running speed by setting a minimum allowed fan current load.

If you wish to set a minimum fan running speed, adjust the fans to the desired speed settings and then press buttons **19 & 18 together**. This will change the "minimum trip current" setting from the default 35mA to be that being used by the fans at your set speed.

Pressing button **19** (Fan comm) alone will display the new "minimum trip current" value. If the fan load drops below that level for more than 10 seconds the system will give an alert and isolate the gas supply. There is a 20% allowance for fluctuations in fan load due to temperature etc.

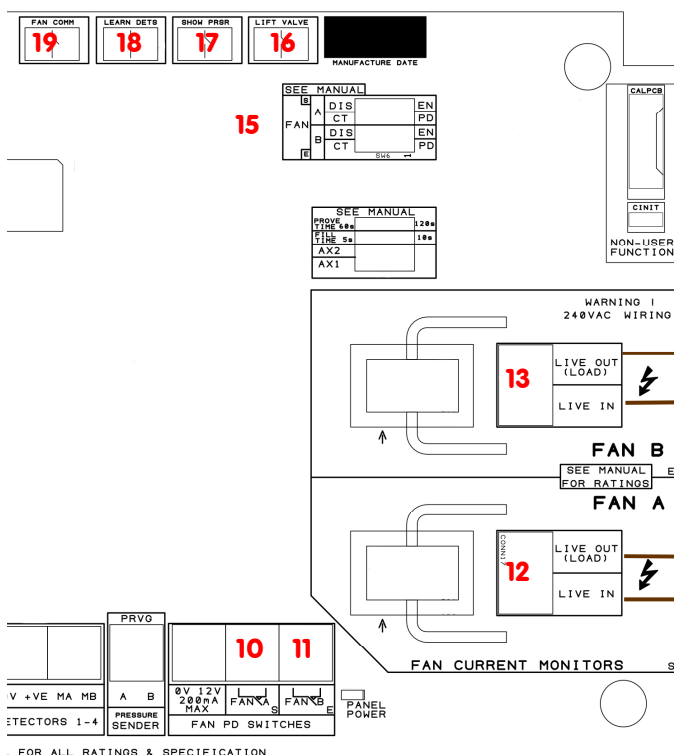

Current Monitoring or PD Switch No15

Fan A CT/PD to select between using CT **12** or Terminal **10** for PD switch.
 Fan B CT/PD to select between using CT **13** or Terminal **11** for PD switch.
 Fan B can be disabled/enabled using the Fan B DIS/EN selector.
 Note: Fan A cannot be disabled, Fan A DIS/EN has no function.

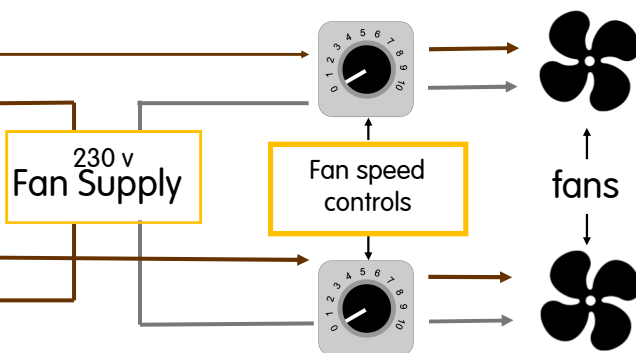

Earth Connections not shown

Where using 3 phase fans interlock on a single phase

medem SafeAir CM (GP)

Pressure Sender & Valve connection

Direction of flow

Ensure that the valve is correctly installed with regard to the direction of the flow of gas and that the Sender Unit is fitted the correct way round. (Note: there is no flow "through" the pressure sender unit, it is purely reading the pressures either side of the valve).

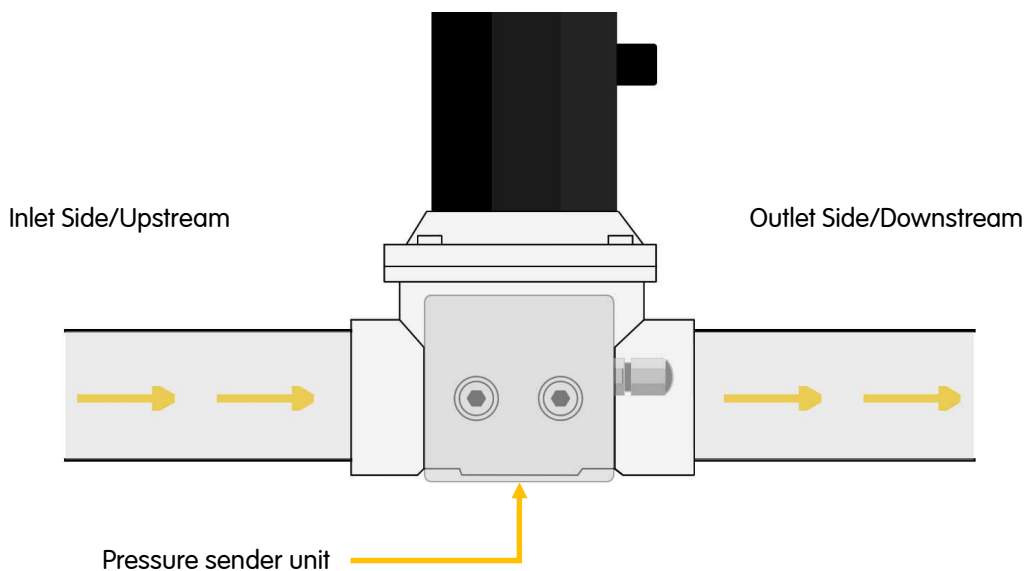

Gas Solenoid and Sender Unit Mounting

Never mount the valve such that the Solenoid or Sender Unit are below the horizontal.

Correct

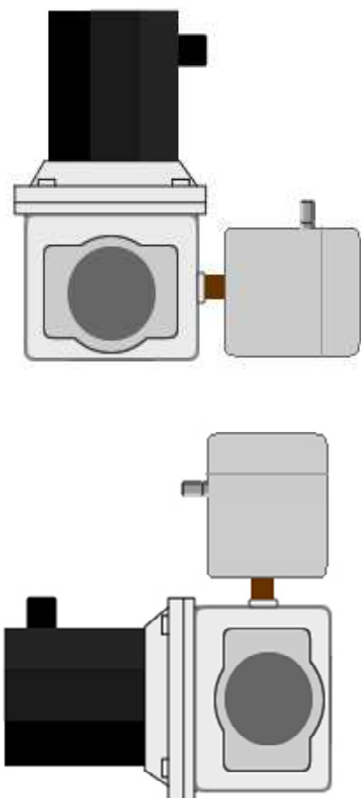

Incorrect

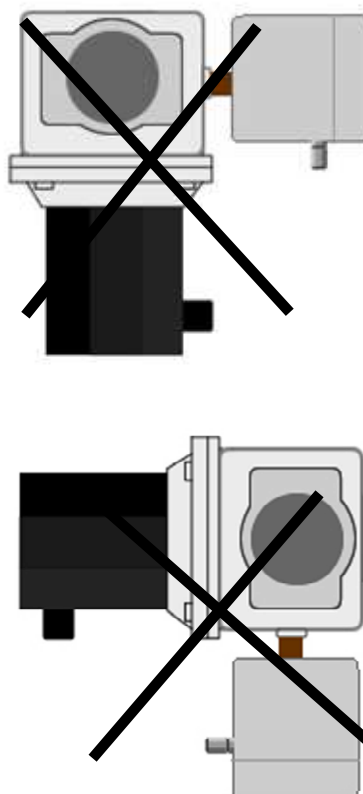



SafeAir CM (GP)

Fitting Kit

Mounting details - Fitting kit

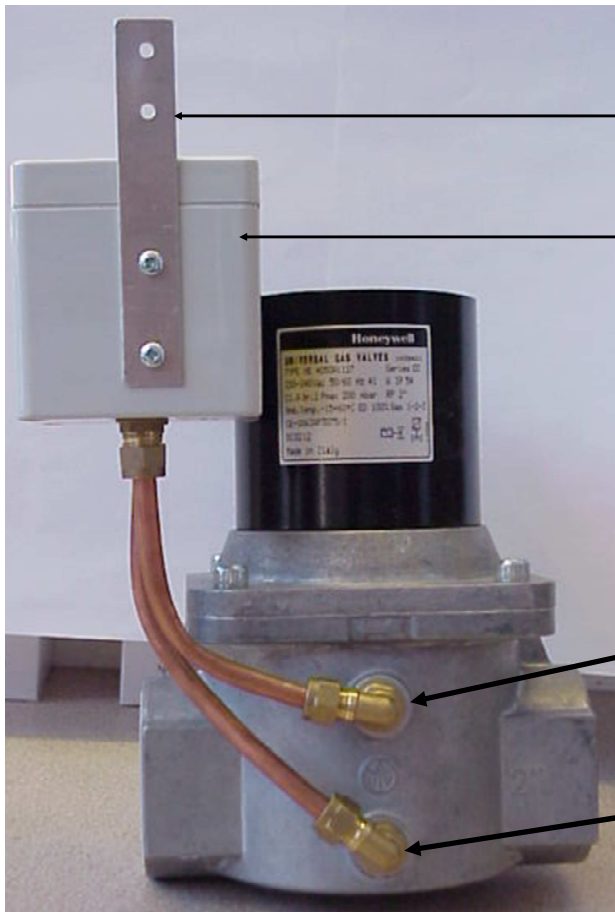

WALL MOUNTING STRAP

PRESSURE SENDER UNIT

INLET PORT & OUTLET PORT
Note: These ports could be side by side

INLET PORT

OUTLET PORT
Note: If this port is blanked off, use port on base of valve.

NOTES:

Solenoid coil of the valve should never be mounted below the horizontal.

Pressure sender unit should never be mounted upside down (to protect from water ingress)

Fitting kit - Contents



Approx 400mm length

Single Stop Buttons

Remote stop buttons can be connected to the panel terminal marked as "EM STOP" (number 6).

The remote buttons must be wired as shown in order to provide a "closed contact" for the control panel.

If thermal links are to be installed these should be wired in series with the EM stop buttons

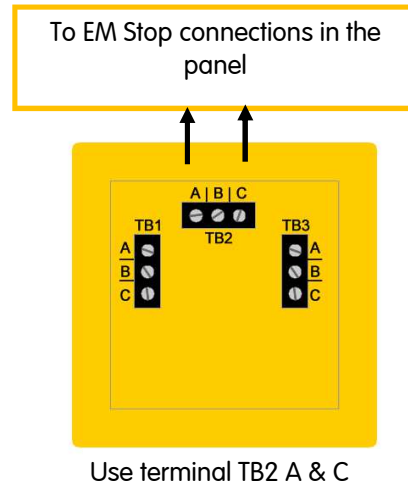

Multiple Stop Buttons

Multiple stop buttons are wired in series.

If thermal links are to be installed these too should be wired in series with the EM stop buttons

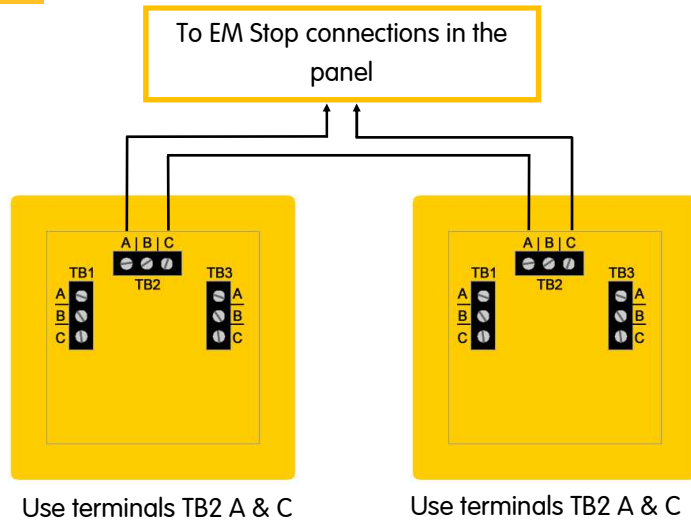

Resetting (indicator bar)

The stop buttons supplied by Medem are of a "Push Glass, key resettable" style, when activated a yellow indicator bar will show and the unit will require resetting using the key provided.

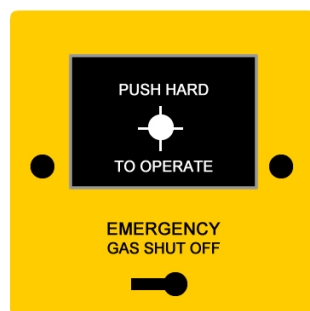

Normal

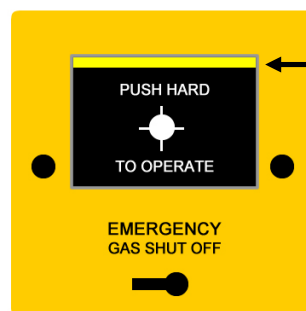

EM-Stop Activated

Medem (UK) Limited
Project House
19 Dallimore Road
Manchester
M23 9NX

Tel: (0) 161 233 0600
Fax: (0) 161 233 0601
Web: www.medem.co.uk
E-mail: sales@medem.co.uk

Medem UK Warranty Terms & Conditions

1. The warranty is a parts warranty and Medem UK Ltd will not cover or accept any labour or other expenses that may be incurred in the process of changing faulty product.
2. All panels and sender units are covered by a five year warranty.
3. Gas detector units and other remote detectors carry a two year warranty. Installation of the detectors should not be undertaken until all building and construction work is completed.
4. Gas solenoid valves carry the original manufacturers warranty, though as the supplier Medem UK will exchange faulty valves for return to the manufacturer.
5. Where a Medem UK engineer (or another company appointed by Medem UK) commission and installed system then that system will carry a ten year warranty. This applies to the main panel and the sender unit. At the time of commissioning a security label with a serial number will be attached to the main panel box. photographs and a comprehensive record of the installation will be held by Medem UK.
6. Where a warranty claim is made then, where appropriate, a written order to attend site must be provided to Medem UK A cost for labour and travel to site will be prepared as a quote. The cost must be included in the order.
7. Where it is found that the installation and/or the quality of workmanship has contributed to or wholly caused the failure of the product then we reserve the right to charge the whole or a proportion of the cost of the faulty item.

In the event of any alert the system will always give a reason on screen as to the cause.

Common messages you may receive are shown below with further explanation.

If you require any help or if anything is unclear then please contact technical support on 0161 233 0600

Test fail check all appliances are off and retest:

The system has found an escape of gas, the most common cause is an open appliance. Check all appliances are off and restart the pressure test. If the system still reports test fail then a leak will be on the pipe work. Using "Blind button A" (see page 2) you can view the gas pressures at the valve, the outlet pressure must remain at least 90% of the value of the inlet pressure or a leak will be declared.

Sender error, call engineer

System is not receiving data from the sender unit. The pressure sender is a required part of the system and cannot be "linked out". Verify the sender is correctly wired and that you have a green flashing LED on the sender unit.

Detector fault, DXX lost comms

The system believes it has lost connection to a detector on address XX, verify detector addresses and press the "learn button" (16). Verify all connected detectors are being registered by pressing "blind button B" (see page 2). If you have no detectors connected to the system pressing the learn button will clear the error message.

Gas Off, Switch On Fan X.

The system can monitor the fan status via a current monitor or air pressure switches. These provide a closed contact to terminals Fan A and Fan B, it is a requirement when using fan interlocking that the fans be running (and therefore the A and B1 receiving a closed contact) before the system can begin a gas pressure test. If at any point the fans stop running (opening the A or B contact) the system will isolate the gas and report fans not running. Check that the fans are not only switched on, but actually running and moving air.

Prs X.XMbar, Check Inlet Gas

The system requires a minimum of 13 mBar of pressure at the inlet side of the gas valve, this is to ensure a correct strength flame. If at any time the incoming pressure drops below 13mBar for more than 10 seconds the system will isolate the gas and report "low incoming gas pressure"

Note: if this occurs during installation check the sender unit direction of flow, if the sender is installed backwards the system will believe the "outlet" to be the "inlet" and therefore see an open end as being low incoming gas pressure.

Gas Off, Reset Em Stops & Switch On/Off

The system has an panel mounted emergency stop and connection inside for remote buttons. First check the panel button (once pressed some require resetting by twisting and releasing). Clear the message by turning the main system switch off and then back on, if the message remains check any remote buttons and their connections. The terminal for the remote buttons requires a volt free normally closed contact, ensure all remote stop buttons, thermal links any another connected systems (BMS/Fire panels) are reset and the contacts are closed.